



*Wall mounted luminaire,  
with plain and accurate design,  
for outdoor applications.*

### **Technical Features**

- Body from aluminium, painted electrostatically in selected colour.
- Tempered protection glass 2mm.
- For recessed installation at concrete.
- Pure light without IR/UV radiation.
- Operation life: 50,000 hours with efficiency > 80% of the initial luminous flux (L80B10).

### **Upon Request**

- Available at 2700K.
- Available with highest colour rendering index (CRI).

# NEST VERTICAL

Outdoor

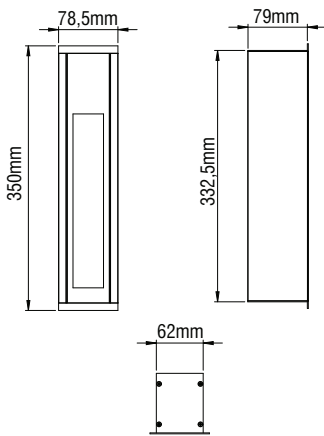

- Aluminium body.
- 4W power consumption driven at 700mA.
- CRI: min. 80 / SDCM: 3.
- Luminous Efficacy:  
4W: 4000 K: 152 Lm/Watt  
4W: 3000 K: 142 Lm/Watt

Code	Description
85817	Nest Vertical 4W IP65 Warm
85818	Nest Vertical 4W IP65 Neutral

**Colour Codes:**

0 Colours 1 White 2 Titan 3 Black